

Exp:

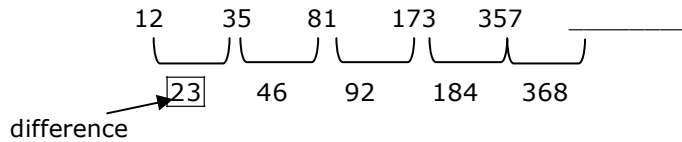

$$\begin{array}{r} 357 \\ \Rightarrow 368 \\ \hline 725 \end{array}$$

Q. No. 6 – 10 Carry One Mark Each

6. Find the odd one from the following group:

- | | | | |
|-------------|-------------|-------------|-------------|
| W,E,K,O | I,Q,W,A | F,N,T,X | N,V,B,D |
| (A) W,E,K,O | (B) I,Q,W,A | (B) F,N,T,X | (D) N,V,B,D |

Answer: (D)

Exp:

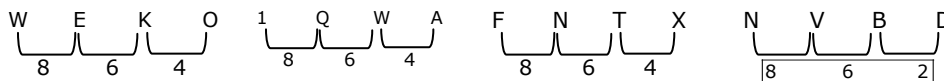

Difference of position: D

7. For submitting tax returns, all resident males with annual income below Rs 10 lakh should fill up Form P and all resident females with income below Rs 8 lakh should fill up Form All people with incomes above Rs 10 lakh should fill up Form R, except non residents with income above Rs 15 lakhs, who should fill up Form S. All others should fill Form T. An example of a person who should fill Form T is

- (A) a resident male with annual income Rs 9 lakh
- (B) a resident female with annual income Rs 9 lakh
- (C) a non-resident male with annual income Rs 16 lakh
- (D) a non-resident female with annual income Rs 16 lakh

Answer: (B)

Exp: Resident female in between 8 to 10 lakhs haven't been mentioned.

8. A train that is 280 metres long, travelling at a uniform speed, crosses a platform in 60 seconds and passes a man standing on the platform in 20 seconds. What is the length of the platform in metres?

Answer: 560

Exp: For a train to cross a person, it takes 20 seconds for its 280m.

So, for second 60 seconds. Total distance travelled should be 840. Including 280 train length so length of plates =840-280=560

9. The exports and imports (in crores of Rs.) of a country from 2000 to 2007 are given in the following bar chart. If the trade deficit is defined as excess of imports over exports, in which year is the trade deficit 1/5th of the exports?

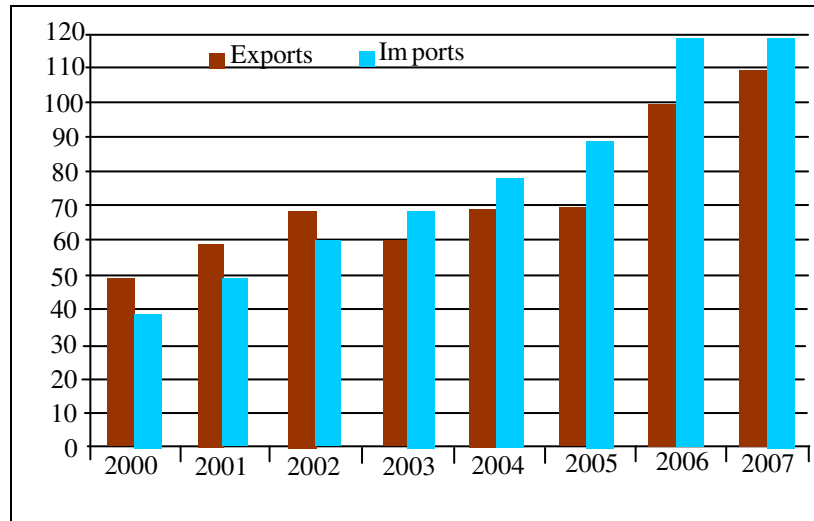

- (A) 2005 (B) 2004 (C) 2007 (D) 2006

Answer: (D)

Exp:

$$2004, \frac{\text{imports} - \text{exports}}{\text{exports}} = \frac{10}{70} = \frac{1}{7}$$

$$2005, \frac{26}{76} = \frac{2}{7}$$

$$2006, \frac{20}{100} = \frac{1}{5}$$

$$2007, \frac{10}{100} = \frac{1}{10}$$

10. You are given three coins: one has heads on both faces, the second has tails on both faces, and the third has a head on one face and a tail on the other. You choose a coin at random and toss it, and it comes up heads. The probability that the other face is tails is

- (A) 1/4 (B) 1/3 (C) 1/2 (D) 2/3

Answer: (B)

Q. No. 1 – 25 Carry One Mark Each

1. For matrices of same dimension M, N and scalar c, which one of these properties DOES NOT ALWAYS hold?

- (A) $(M^T)^T = M$ (B) $(cM^T)^T = c(M)^T$
 (C) $(M + N)^T = M^T + N^T$ (D) $MN = NM$

Answer: (D)

Exp: Matrix multiplication is not commutative in general.

2. In a housing society, half of the families have a single child per family, while the remaining half have two children per family. The probability that a child picked at random, has a sibling is _____

Answer: 0.667

Exp: Let $E_1 =$ one children family

$E_2 =$ two children family and

A = picking a child then by Baye's theorem, required probability is

$$P\left(\frac{E_2}{A}\right) = \frac{\frac{1}{2} \cdot x}{\frac{1}{2} \cdot \frac{x}{2} + \frac{1}{2} \cdot x} = \frac{2}{3} = 0.667$$

(Here 'x' is number of families)

3. C is a closed path in the z-plane given by $|z|=3$. The value of the integral $\oint_C \left(\frac{z^2 - z + 4j}{z + 2j} \right) dz$ is

- (A) $-4\pi(1 + j2)$ (B) $4\pi(3 - j2)$ (C) $-4\pi(3 + j2)$ (D) $4\pi(1 - j2)$

Answer: (C)

Exp: $Z = -2j$ is a singularity lies inside $C : |Z| = 3$

∴ By Cauchy's integral formula,

$$\oint_C \frac{Z^2 - Z + 4j}{Z + 2j} dz = 2\pi j \cdot [Z^2 - Z + 4j]_{Z=-2j}$$

$$= 2\pi j[-4 + 2j + 4j] = -4\pi[3 + j2]$$

4. A real (4×4) matrix A satisfies the equation $A^2 = I$, where I is the (4×4) identity matrix. The positive eigen value of A is _____.

Answer: 1

Exp: $A^2 = I \Rightarrow A = A^{-1} \Rightarrow$ if λ is on eigen value of A then $\frac{1}{\lambda}$ is also its eigen value. Since, we require positive eigen value. ∴ $\lambda = 1$ is the only possibility as no other positive number is self inverted

5. Let X_1 , X_2 , and X_3 be independent and identically distributed random variables with the uniform distribution on $[0, 1]$. The probability $P\{X_1 \text{ is the largest}\}$ is _____

Answer: 0.32-0.34

6. For maximum power transfer between two cascaded sections of an electrical network, the relationship between the output impedance Z_1 of the first section to the input impedance Z_2 of the second section is

(A) $Z_2 = Z_1$ (B) $Z_2 = -Z_1$ (C) $Z_2 = Z_1^*$ (D) $Z_2 = -Z_1^*$

Answer: (C)

Exp: Two cascaded sections

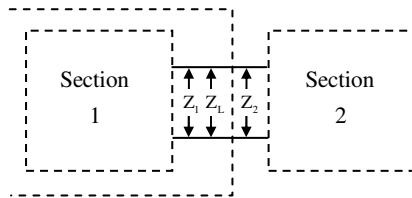

Z_1 = Output impedance of first section

Z_2 = Input impedance of second section

For maximum power transfer, upto 1st section is

$$Z_L = Z_1^*$$

$$Z_L = Z_2 \Rightarrow Z_2 = Z_1^*$$

7. Consider the configuration shown in the figure which is a portion of a larger electrical network

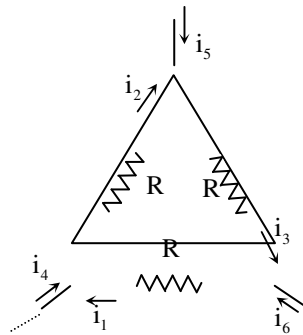

For $R = 1\Omega$ and currents $i_1 = 2A$, $i_4 = -1A$, $i_5 = -4A$, which one of the following is TRUE?

- (A) $i_6 = 5 A$
 (B) $i_3 = -4A$
 (C) Data is sufficient to conclude that the supposed currents are impossible
 (D) Data is insufficient to identify the current i_2, i_3 , and i_6

Answer: (A)

Exp: Given $i_1 = 2A$

$$i_4 = -1A$$

$$i_3 = -4A$$

KCL at node A, $i_1 + i_4 = i_2$

$$\Rightarrow i_2 = 2 - 1 = 1A$$

1. KCL at node B, $i_2 + i_5 = i_3$

$$\Rightarrow i_3 = 1 - 4 = -3A$$

KCL at node C, $i_3 + i_6 = i_1$

$$\Rightarrow i_6 = 2 - (-3) = 5A$$

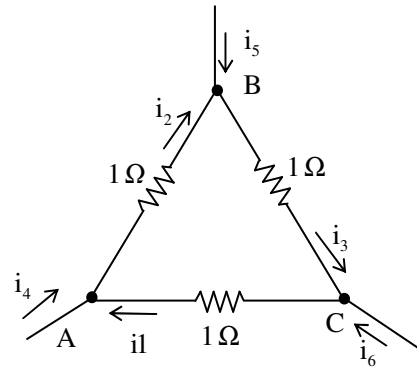

8. When the optical power incident on a photodiode is $10\mu W$ and the responsivity is $0.8 A/W$, the photocurrent generated (in μA) is _____.

Answer: 8

Exp: Responsivity $(R) = \frac{I_p}{P_0}$

$$0.8 = \frac{I_p}{10 \times 10^{-6}}$$

$$\Rightarrow I_p = 8\mu A$$

9. In the figure, assume that the forward voltage drops of the PN diode D_1 and Schottky diode D_2 are $0.7 V$ and $0.3 V$, respectively. If ON denotes conducting state of the diode and OFF denotes non-conducting state of the diode, then in the circuit,

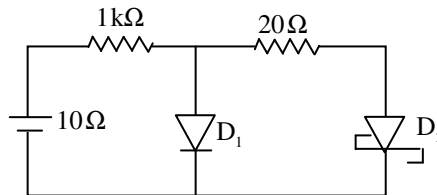

(A) both D_1 and D_2 are ON

(B) D_1 is ON and D_2 is OFF

(C) both D_1 and D_2 are OFF

(D) D_1 is OFF and D_2 is ON

Answer: (D)

Exp: Assume both the diode ON.

Then circuit will be as per figure (2)

$$\therefore I = \frac{10 - 0.7}{1k} = 9.3mA$$

$$I_{D_2} = \frac{0.7 - 0.3}{20} = 20mA$$

$$\text{Now, } I_{D_1} = I - I_{D_2}$$

$$= -10.7mA \text{ (Not possible)}$$

$\therefore D_1$ is OFF and hence D_2 - ON

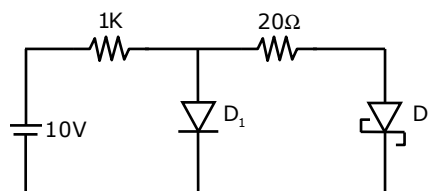

Figure(1)

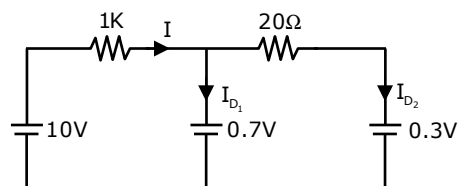

10. If fixed positive charges are present in the gate oxide of an n-channel enhancement type MOSFET, it will lead to
 (A) a decrease in the threshold voltage (B) channel length modulation
 (C) an increase in substrate leakage current (D) an increase in accumulation capacitance

Answer: (A)

11. A good current buffer has
 (A) low input impedance and low output impedance
 (B) low input impedance and high output impedance
 (C) high input impedance and low output impedance
 (D) high input impedance and high output impedance

Answer: (B)

Exp: Ideal current Buffer has $Z_i = 0$

$$Z_o = \infty$$

12. In the ac equivalent circuit shown in the figure, if i_{in} is the input current and R_F is very large, the type of feedback is

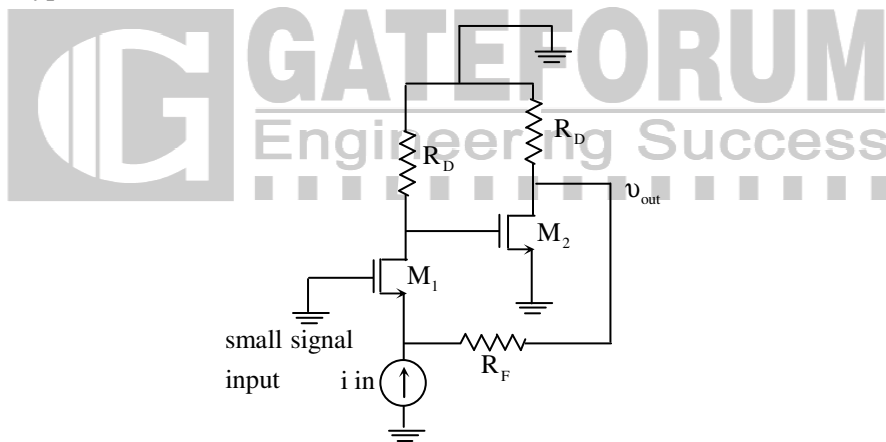

- (A) voltage-voltage feedback (B) voltage-current feedback
 (C) current-voltage feedback (D) current-current feedback

Answer: (B)

Exp: Output sample is voltage and is added at the input or current

∴ It is voltage – shunt negative feedback i.e, voltage-current negative feedback

13. In the low-pass filter shown in the figure, for a cut-off frequency of 5kHz, the value of R_2 (in k Ω) is _____.

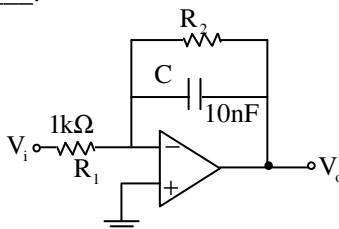

Answer: 3.18

Exp: $f = 5 \text{ KHz}$

$$\text{Cut off frequency (LPF)} = \frac{1}{2\pi R_2 C} = 5 \text{ KHz}$$

$$\Rightarrow R_2 = \frac{1}{2\pi \times 5 \times 10^3 \times 10 \times 10^{-9}} = 3.18 \text{ k}\Omega$$

14. In the following circuit employing pass transistor logic, all NMOS transistors are identical with a threshold voltage of 1 V. Ignoring the body-effect, the output voltages at P, Q and R are,

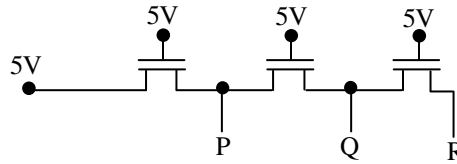

(A) 4 V, 3 V, 2 V

(B) 5 V, 5 V, 5 V

(C) 4 V, 4 V, 4 V

(D) 5 V, 4 V, 3 V

Answer: (C)

Exp: Assume all NMOS are in saturation

$$\therefore V_{DS} \geq (V_{GS} - V_T)$$

For m_1

$$(5 - V_p) \geq (5 - V_p - 1)$$

$$(5 - V_p) > (4 - V_p) \Rightarrow \text{Sat}$$

$$\therefore I_{D_1} = k(V_{GS} - V_T)^2$$

$$I_{D_1} = K(4 - V_p)^2 \dots\dots(1)$$

For m_2 ,

$$I_{D_1} = K(5 - V_Q - 1)^2$$

$$I_{D_2} = K(4 - V_Q)^2 \dots\dots(2)$$

$$\therefore I_{D_1} = I_{D_2}$$

$$(4 - V_p)^2 = (4 - V_Q)^2$$

$$\Rightarrow V_p = V_Q \text{ \& } V_p + V_Q = 8$$

$$\Rightarrow V_p = V_Q = 4 \text{ V}$$

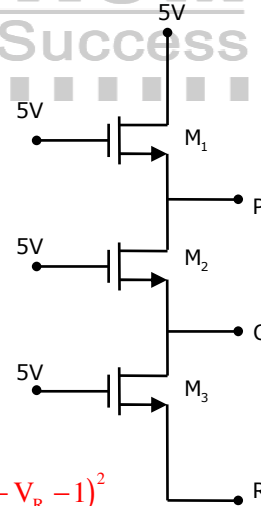

For m_3 ,

$$I_{D_3} = K(5 - V_R - 1)^2$$

$$\therefore I_{D_2} = I_{D_3}$$

$$(4 - V_Q)^2 = (4 - V_R)^2$$

$$\Rightarrow V_R = V_Q = 4 \text{ V}$$

$$\therefore V_p = V_Q = V_R = 4 \text{ V}$$

15. The Boolean expression $(X + Y)(X + \bar{Y}) + \overline{(X + \bar{Y})} + \bar{X}$ simplifies to
 (A) X (B) Y (C) XY (D) X+Y

Answer: (A)

Exp: Given Boolean Expression is $(X + Y)(X + \bar{Y}) + \overline{(X + \bar{Y})} + \bar{X}$

As per the transposition theorem

$$(A + BC) = (A + B)(A + C)$$

$$\text{so, } (X + Y)(X + \bar{Y}) = X + Y\bar{Y} = X + 0$$

$$(X + Y)(X + \bar{Y}) + \overline{(X + \bar{Y})} + \bar{X} = X + (\overline{X\bar{Y}}) + \bar{X}$$

$$= X + (\bar{X} + Y) \cdot X = X + \bar{X}X + Y \cdot X = X + 0 + Y \cdot X$$

$$\text{Apply absorption theorem} = X(1 + Y) = X \cdot 1 = X$$

16. Five JK flip-flops are cascaded to form the circuit shown in Figure. Clock pulses at a frequency of 1 MHz are applied as shown. The frequency (in kHz) of the waveform at Q3 is

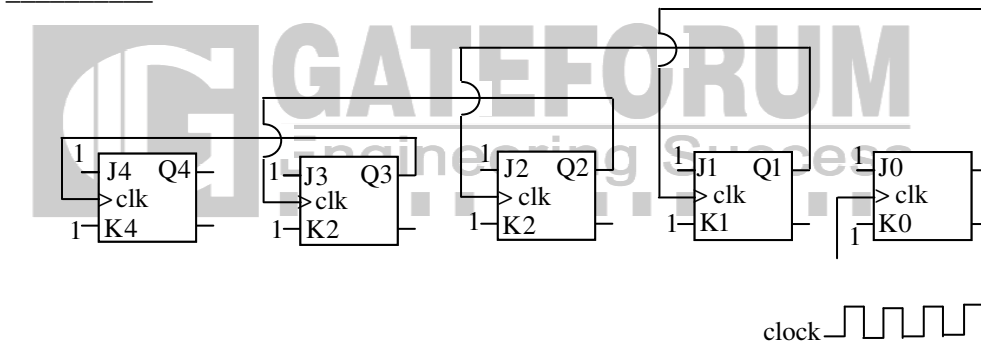

Answer: 62.5

Exp: Given circuit is a Ripple (Asynchronous) counter. In Ripple counter, o/p frequency of each flip-flop is half of the input frequency if their all the states are used otherwise o/p frequency of the counter is $= \frac{\text{input frequency}}{\text{modulus of the counter}}$

$$\begin{aligned} \text{So, the frequency at } Q_3 &= \frac{\text{input frequency}}{16} \\ &= \frac{1 \times 10^6}{16} \text{ Hz} = 62.5 \text{ kHz} \end{aligned}$$

17. A discrete-time signal $x[n] = \sin(\pi^2 n)$, n being an integer, is
 (A) periodic with period π . (B) periodic with period π^2 .
 (C) periodic with period $\pi/2$. (D) not periodic

Answer: (D)

Exp: Assume $x[n]$ to be periodic, (with period N)

$$\Rightarrow x[n] = x[n + N]$$

$$\Rightarrow \sin(\pi^2 n) = \sin(\pi^2 (n + N))$$

Every trigonometric function repeats after 2π interval.

$$\Rightarrow \sin(\pi^2 n + 2\pi k) = \sin(\pi^2 n + \pi^2 N)$$

$$\Rightarrow 2\pi k = \pi^2 N \Rightarrow N = \left(\frac{2k}{\pi}\right)$$

Since 'k' is any integer, there is no possible value of 'k' for which 'N' can be an integer, thus non-periodic.

18. Consider two real valued signals, $x(t)$ band-limited to $[-500 \text{ Hz}, 500 \text{ Hz}]$ and $y(t)$ band-limited to $[-1 \text{ kHz}, 1 \text{ kHz}]$. For $z(t) = x(t) \cdot y(t)$, the Nyquist sampling frequency (in kHz) is _____

Answer: 3

Exp: $x(t)$ is band limited to $[-500 \text{ Hz}, 500 \text{ Hz}]$

$y(t)$ is band limited to $[-1000 \text{ Hz}, 1000 \text{ Hz}]$

$$z(t) = x(t) \cdot y(t)$$

Multiplication in time domain results convolution in frequency domain.

The range of convolution in frequency domain is $[-1500 \text{ Hz}, 1500 \text{ Hz}]$

So maximum frequency present in $z(t)$ is 1500 Hz Nyquist rate is 3000 Hz or 3 kHz

19. A continuous, linear time-invariant filter has an impulse response $h(t)$ described by

$$h(t) = \begin{cases} 3 & \text{for } 0 \leq t \leq 3 \\ 0 & \text{otherwise} \end{cases}$$

When a constant input of value 5 is applied to this filter, the steady state output is _____.

Answer: 45

Exp:

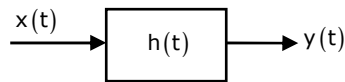

$$y(t) = x(t) * h(t)$$

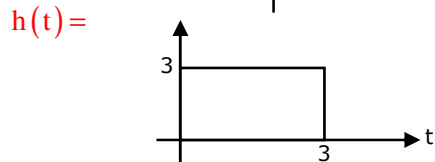
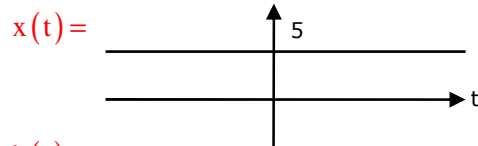

$$y(t) = \int_0^3 3 \cdot 5 \cdot d\tau = 45 \text{ (steady state output)}$$

20. The forward path transfer function of a unity negative feedback system is given by

$$G(s) = \frac{K}{(s+2)(s-1)}$$

The value of K which will place both the poles of the closed-loop system at the same location, is _____.

Answer: 2.25

Exp: Given $G(s) = \frac{K}{(s+2)(s-1)}$

$$H(s) = 1$$

Characteristic equation: $1 + G(s)H(s) = 0$

$$1 + \frac{K}{(s+2)(s-1)} = 0$$

The poles are $s_{1,2} = -1 \pm \sqrt{\frac{9}{4} - 4K}$

If $\frac{9}{4} - 4K = 0$, then both poles of the closed loop system at the same location.

So, $K = \frac{9}{4} \Rightarrow 2.25$

21. Consider the feedback system shown in the figure. The Nyquist plot of $G(s)$ is also shown. Which one of the following conclusions is correct?

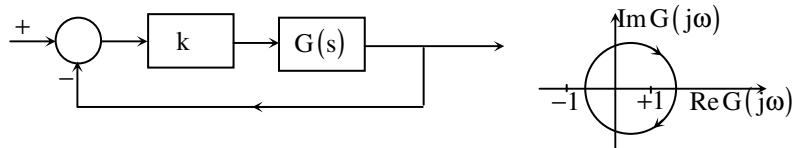

- (A) $G(s)$ is an all-pass filter
- (B) $G(s)$ is a strictly proper transfer function
- (C) $G(s)$ is a stable and minimum-phase transfer function
- (D) The closed-loop system is unstable for sufficiently large and positive k

Answer: (D)

Exp: For larger values of K, it will encircle the critical point $(-1+j0)$, which makes closed-loop system unstable.

22. In a code-division multiple access (CDMA) system with $N = 8$ chips, the maximum number of users who can be assigned mutually orthogonal signature sequences is _____

Answer: 7.99 to 8.01

Exp: Spreading factor(SF) = $\frac{\text{chip rate}}{\text{symbol rate}}$

This if a single symbol is represented by a code of 8 chips

Chip rate = 80 × symbol rate

S.F (Spreading Factor) = $\frac{8 \times \text{symbol rate}}{\text{symbol rate}} = 8$

Spread factor (or) process gain and determine to a certain extent the upper limit of the total number of uses supported simultaneously by a station.

23. The capacity of a Binary Symmetric Channel (BSC) with cross-over probability 0.5 is _____

Answer: 0

Exp: Capacity of channel is $1 - H(p)$

$H(p)$ is entropy function

With cross over probability of 0.5

$H(p) = \frac{1}{2} \log_2 \frac{1}{0.5} + \frac{1}{2} \log_2 \frac{1}{0.5} = 1$

$\Rightarrow \text{Capacity} = 1 - 1 = 0$

24. A two-port network has scattering parameters given by $[S] = \begin{bmatrix} S_{11} & S_{12} \\ S_{21} & S_{22} \end{bmatrix}$. If the port-2 of the two-port is short circuited, the S_{11} parameter for the resultant one-port network is

(A) $\frac{S_{11} - S_{11} S_{22} + S_{12} S_{21}}{1 + S_{22}}$

(B) $\frac{S_{11} - S_{11} S_{22} - S_{12} S_{21}}{1 + S_{22}}$

(C) $\frac{S_{11} - S_{11} S_{22} + S_{12} S_{21}}{1 - S_{22}}$

(D) $\frac{S_{11} - S_{11} S_{22} - S_{12} S_{21}}{1 - S_{22}}$

Answer:(B)

Exp:

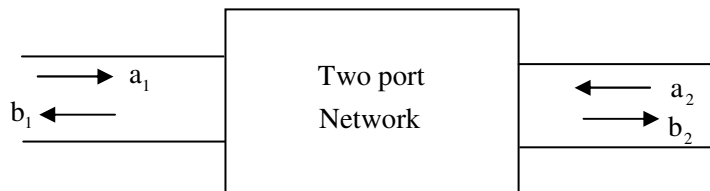

$b_1 = s_{11} a_1 + s_{12} a_2$

$b_2 = s_{21} a_1 + s_{22} a_2$

$\begin{bmatrix} b_1 \\ b_2 \end{bmatrix} = \begin{bmatrix} s_{11} & s_{12} \\ s_{21} & s_{22} \end{bmatrix} \begin{bmatrix} a_1 \\ a_2 \end{bmatrix}; \quad s_{11} = \left. \frac{b_1}{a_1} \right|_{a_2=0}$

By verification Answer B satisfies.

25. The force on a point charge +q kept at a distance d from the surface of an infinite grounded metal plate in a medium of permittivity ϵ is

- (A) 0
 (B) $\frac{q^2}{16\pi\epsilon d^2}$ away from the plate
 (C) $\frac{q^2}{16\pi\epsilon d^2}$ towards the plate
 (D) $\frac{q^2}{4\pi\epsilon d^2}$ towards the plate

Answer:(C)

Exp: $F = \frac{1}{4\pi\epsilon} \frac{Q_1 Q_2}{R^2}$
 $F = \frac{1}{4\pi\epsilon} \frac{q^2}{(2d)^2} = \frac{q^2}{16\pi\epsilon d^2}$

Since the charges are opposite polarity
 the force between them is attractive.

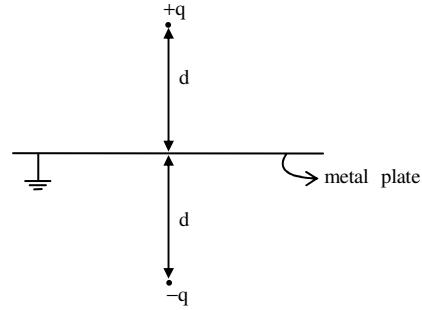

Q.No. 26 – 55 Carry Two Marks Each

26. The Taylor series expansion of $3 \sin x + 2 \cos x$ is

- (A) $2 + 3x - x^2 - \frac{x^3}{2} + \dots$ (B) $2 - 3x + x^2 - \frac{x^3}{2} + \dots$
 (C) $2 + 3x + x^2 + \frac{x^3}{2} + \dots$ (D) $2 - 3x - x^2 + \frac{x^3}{2} + \dots$

Answer: (A)

Exp: $3 \sin x + 2 \cos x = 3 \left(x - \frac{x^3}{3!} + \dots \right) + 2 \left(1 - \frac{x^2}{2!} + \dots \right)$
 $= 2 + 3x - x^2 - \frac{x^3}{2} + \dots$

27. For a Function $g(t)$, it is given that $\int_{-\infty}^{+\infty} g(t) e^{-j\omega t} dt = \omega e^{-2\omega^2}$ for any real value ω . If

$y(t) = \int_{-\infty}^t g(\tau) d\tau$, then $\int_{-\infty}^{+\infty} y(t) dt$ is

- (A) 0 (B) -j (C) $-\frac{j}{2}$ (D) $\frac{j}{2}$

Answer: (B)

Exp: Given

$\int_{-\infty}^{\infty} g(t) e^{-j\omega t} dt = \omega e^{-2\omega^2}$ (let $G(j\omega)$)
 $\Rightarrow \int_{-\infty}^{\infty} g(t) dt = 0$

$$y(t) = \int_{-\infty}^t g(z).dz \Rightarrow y(t) = g(t) * u(t) \text{ [} u(t) \text{ in unit step function]}$$

$$\Rightarrow Y(j\omega) = G(j\omega).U(j\omega)$$

$$Y(j\omega) = \int_{-\infty}^{\infty} y(t).e^{-j\omega t} dt$$

$$\Rightarrow Y(j\omega) = \int_{-\infty}^{\infty} y(t) dt = \left[\omega e^{-2j\omega} \left[\frac{1}{j\omega} + \pi\delta(\omega) \right] \right]_{\omega=0}$$

$$= \frac{1}{j} = -j$$

28. The volume under the surface $z(x, y) = x + y$ and above the triangle in the x - y plane defined by $\{0 \leq y \leq x \text{ and } 0 \leq x \leq 12\}$ is _____.

Answer: 864

Exp: Volume = $\iint_R Z(x, y) dy dx = \int_{x=0}^{12} \int_{y=0}^x (x + y) dy dx$

$$= \int_{x=0}^{12} \left[xy + \frac{y^2}{2} \right]_0^x dx = \int_0^{12} \frac{3}{2} x^2 dx = \frac{3}{2} \left[\frac{x^3}{3} \right]_0^{12} = 864$$

29. Consider the matrix:

$$J_6 = \begin{pmatrix} 0 & 0 & 0 & 0 & 0 & 1 \\ 0 & 0 & 0 & 0 & 1 & 0 \\ 0 & 0 & 0 & 1 & 0 & 0 \\ 0 & 0 & 1 & 0 & 0 & 0 \\ 0 & 1 & 0 & 0 & 0 & 0 \\ 1 & 0 & 0 & 0 & 0 & 0 \end{pmatrix}$$

Which is obtained by reversing the order of the columns of the identity matrix I_6 .

Let $P = I_6 + \alpha J_6$, where α is a non-negative real number. The value of α for which $\det(P) = 0$ is _____.

Answer: 1

Exp: Consider, (i) Let $P = I_2 + \alpha J_2 = \begin{bmatrix} 1 & 0 \\ 0 & 1 \end{bmatrix} + \alpha \begin{bmatrix} 0 & 1 \\ 1 & 0 \end{bmatrix} = \begin{bmatrix} 1 & \alpha \\ \alpha & 1 \end{bmatrix}$

$$\Rightarrow |P| = 1 - \alpha^2$$

(ii) Let $P = I_4 + \alpha J_4 = \begin{bmatrix} 1 & 0 & 0 & \alpha \\ 0 & 1 & \alpha & 0 \\ 0 & \alpha & 1 & 0 \\ \alpha & 0 & 0 & 1 \end{bmatrix}$

$$|P| = (1) \begin{vmatrix} 1 & \alpha & 0 \\ \alpha & 1 & 0 \\ 0 & 0 & 1 \end{vmatrix} - (\alpha) \begin{vmatrix} 0 & 1 & \alpha \\ 0 & \alpha & 1 \\ \alpha & 0 & 0 \end{vmatrix}$$

$$= (1 - \alpha^2) - (\alpha) [\alpha (1 - \alpha^2)] = (1 - \alpha^2)^2$$

Similarly, if $P = I_6 + \alpha J_6$ then we get

$$|P| = (1 - \alpha^2)^3$$

$$\therefore |P| = 0 \Rightarrow \alpha = -1, 1$$

$\therefore \alpha$ is non negative

$$\therefore \alpha = 1$$

30. A Y-network has resistances of 10Ω each in two of its arms, while the third arm has a resistance of 11Ω in the equivalent Δ -network, the lowest value (in Ω) among the three resistances is _____.

Answer: 29.09Ω

Exp:

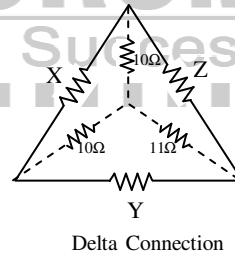
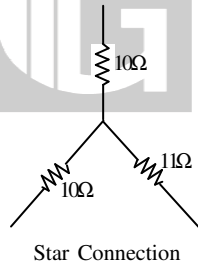

$$X = 29.09\Omega$$

$$y = 32\Omega$$

$$z = 32\Omega$$

$$X = \frac{(10)(10) + (10)(11) + (10)(11)}{11} \Omega$$

$$y = \frac{(10)(10) + (10)(11) + (10)(11)}{10} \Omega$$

$$z = \frac{(10)(10) + (10)(11) + (10)(11)}{10} \Omega$$

i.e, lowest value among three resistances is 29.09Ω

31. A 230 V rms source supplies power to two loads connected in parallel. The first load draws 10 kW at 0.8 leading power factor and the second one draws 10 kVA at 0.8 lagging power factor. The complex power delivered by the source is

(A) $(18 + j 1.5)$ kVA

(B) $(18 - j 1.5)$ kVA

(C) $(20 + j 1.5)$ kVA

(D) $(20 - j 1.5)$ kVA

Answer: (B)

Exp:

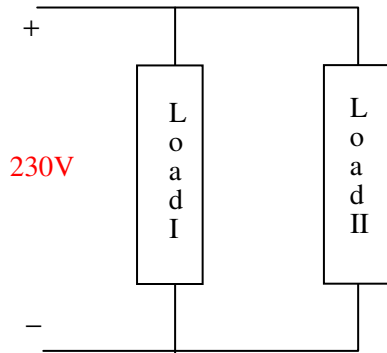

Load 1:

$$\left. \begin{aligned} P &= 10 \text{ kW} \\ \cos \phi &= 0.8 \\ Q &= P \tan \phi = 7.5 \text{ KVAR} \end{aligned} \right\} S_1 = P - jQ = 10 - j7.5 \text{ KVA}$$

Load 2: $S = 10 \text{ KVA}$

$$\cos \phi = 0.8 \quad \sin \phi = \frac{Q}{S}$$

$$\cos \phi = \frac{P}{S}$$

$$0.8 = \frac{P}{10} \rightarrow P = 8 \text{ kW} \quad Q = 6 \text{ KVAR}$$

$$S_1 = P + jQ = 8 + j6$$

Complex power delivered by the source is $S_1 + S_2 = 18 - j1.5 \text{ KVA}$

32. A periodic variable x is shown in the figure as a function of time. The root-mean-square (rms) value of x is _____.

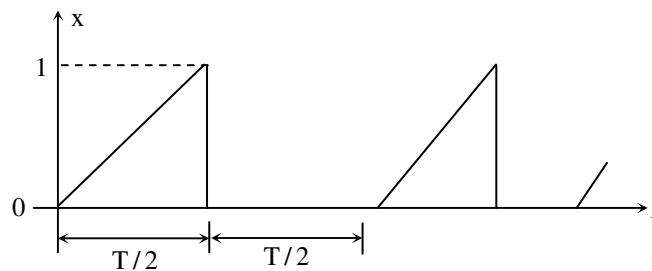

Answer: 0.408

$$\begin{aligned} \text{Exp: } x_{\text{rms}} &= \sqrt{\frac{1}{T} \int_0^T (x(t))^2 dt} \\ x(t) &= \begin{cases} \frac{2}{T}t & 0 \leq t \leq T/2 \\ 0 & T/2 \leq t \leq T \end{cases} \\ &= \sqrt{\frac{1}{T} \left[\int_0^{T/2} \left(\frac{2}{T}t\right)^2 dt + \int_{T/2}^T (0)^2 dt \right]} \\ &= \sqrt{\frac{1}{T} \cdot \frac{4}{T^2} \left[\frac{t^3}{3} \right]_0^{T/2}} \\ x_{\text{rms}} &= \sqrt{\frac{4}{3T^3} \cdot \frac{T^3}{8}} \Rightarrow \sqrt{\frac{1}{6}} \Rightarrow 0.408 \end{aligned}$$

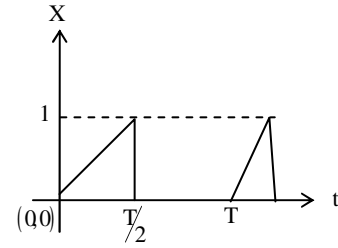

33. In the circuit shown in the figure, the value of capacitor C(in mF) needed to have critically damped response $i(t)$ is _____.

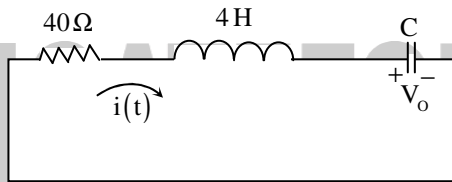

Answer: 10mF

Exp: By KVL,

$$v(t) = Ri(t) + L \cdot \frac{di(t)}{dt} + \frac{1}{C} \int i(t) dt$$

Differentiate with respect to time,

$$0 = \frac{R \cdot di(t)}{dt} + \frac{R}{L} \cdot \frac{di(t)}{dt} + \frac{i(t)}{LC} = 0$$

$$\frac{d^2i(t)}{dt^2} + \frac{R}{L} \cdot \frac{di(t)}{dt} + \frac{i(t)}{LC} = 0$$

$$D_{1,2} = \frac{-R/L \pm \sqrt{\left(\frac{R}{L}\right)^2 - \frac{4}{LC}}}{2}$$

$$D_{1,2} = \frac{-R}{2L} \pm \sqrt{\left(\frac{R}{2L}\right)^2 - \frac{1}{LC}}$$

For critically damped response,

$$\left(\frac{R}{2L}\right)^2 = \frac{1}{LC} \Rightarrow \boxed{C = \frac{4L}{R^2}} \text{ F}$$

Given, $L=4\text{H}$; $R=40\Omega$

$$C = \frac{4 \times 4}{(40)^2} \Rightarrow 10\text{mF}$$

34. A BJT is biased in forward active mode, Assume $V_{BE} = 0.7V$, $kT/q = 25mV$ and reverse saturation current $I_s = 10^{-13}$ A. The transconductance of the BJT (in mA/V) is _____.

Answer: 5.785

Exp: $V_{BE} = 0.7V$, $\frac{kT}{q} = 25mV$, $I_s = 10^{-13}$

Transconductance, $g_m = \frac{I_C}{V_T}$

$I_C = I_s [e^{V_{BE}/V_T} - 1]$
 $= 10^{-13} [e^{0.7/25mV} - 1] = 144.625 mA$

$\therefore g_m = \frac{I_C}{V_T} = \frac{144.625 mA}{25 mV} = 5.785 A / V$

35. The doping concentrations on the p-side and n-side of a silicon diode are $1 \times 10^{16} cm^{-3}$ and $1 \times 10^{17} cm^{-3}$, respectively. A forward bias of 0.3 V is applied to the diode. At $T = 300K$, the intrinsic carrier concentration of silicon $n_i = 1.5 \times 10^{10} cm^{-3}$ and $\frac{kT}{q} = 26mV$. The electron concentration at the edge of the depletion region on the p-side is

- (A) $2.3 \times 10^9 cm^{-3}$ (B) $1 \times 10^{16} cm^{-3}$ (C) $1 \times 10^{17} cm^{-3}$ (D) $2.25 \times 10^6 cm^{-3}$

Answer:(A)

Exp: Electron concentration, $n = \frac{n_i^2}{N_A} e^{V_{bi}/V_T}$
 $= \frac{(1.5 \times 10^{10})^2}{1 \times 10^{16}} e^{0.3/26mV}$
 $= 2.3 \times 10^9 / cm^3$

36. A depletion type N-channel MOSFET is biased in its linear region for use as a voltage controlled resistor. Assume threshold voltage $V_{TH} = 0.5V$, $V_{GS} = 2.0V$, $V_{DS} = 5V$, $W/L = 100$, $C_{OX} = 10^{-8} F/cm^2$ and $\mu_n = 800 cm^2 / V - s$. The value of the resistance of the voltage controlled resistor (in Ω) is _____.

Answer:500

Exp: Given $V_T = -0.5V$; $V_{GS} = 2V$; $V_{DS} = 5V$; $W/L = 100$; $C_{ox} = 10^{-8} f / cm$

$\mu_n = 800 cm^2 / v - s$

$I_D = \frac{1}{2} \mu_n C_{ox} \frac{W}{L} [2(V_{GS} - V_T)V_{DS} - V_{DS}^2]$

$\left[\frac{\partial I_D}{\partial V_{DS}} \right]^{-1} = r_{ds} \left[\frac{\partial}{\partial V_{DS}} \left\{ \frac{1}{2} \mu_n C_{ox} \frac{W}{L} [2(V_{GS} - V_T)V_{DS} - V_{DS}^2] \right\} \right]^{-1}$

$$= \left[\mu_n C_{ox} \frac{W}{L} (V_{GS} - V_T) - \mu_n C_{ox} \frac{W}{L} V_{DS} \right]^{-1}$$

$$\Rightarrow |r_{ds}| = \left| \frac{1}{\mu_n C_{ox} \frac{W}{L} (V_{GS} - V_T - V_{Ds})} \right|$$

$$= \left| \frac{1}{800 \times 10^{-8} \times 100 (2 + 0.5 - 5)} \right| = 500 \Omega$$

37. In the voltage regulator circuit shown in the figure, the op-amp is ideal. The BJT has $V_{BE} = 0.7V$ and $\beta = 100$, and the zener voltage is $4.7V$. For a regulated output of $9V$, the value of R (in Ω) is _____ .

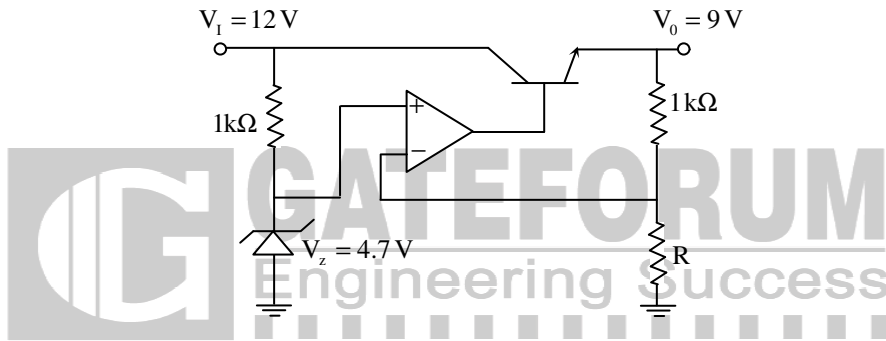

Answer:1093

Exp: Given $V_{BE} = 0.7V$, $\beta = 100$, $V_z = 4.7V$, $V_0 = 9V$

$$V_R = 9 \times \frac{R}{R + 1k}$$

$$4.7 = 9 \times \frac{R}{R + 1k} (\because V_R = V_z)$$

$$R = 1093 \Omega$$

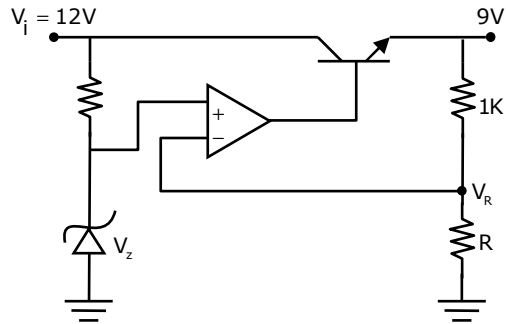

38. In the circuit shown, the op-amp has finite input impedance, infinite voltage gain and zero input offset voltage. The output voltage V_{out} is

- (A) $-I_2 (R_1 + R_2)$
 (B) $I_2 R_2$
 (C) $I_1 R_2$
 (D) $-I_1 (R_1 + R_2)$

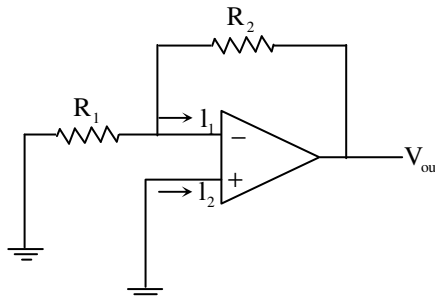

Answer: (C)

Exp: Given, $Z_i = \infty$

$$A_{0L} = \infty$$

$$V_{i_0} = 0$$

$$V_2 = (R_1 / R_2) I_1$$

$$= \frac{R_1 R_2}{R_1 + R_2} I_1 \dots (1)$$

KCL at inverting node

$$\frac{V_2}{R_1} + \frac{V_2 - V_0}{R_2} = 0 \quad (\because Z_i = \infty)$$

$$\frac{V_0}{R_2} = V_2 \left[\frac{1}{R_1} + \frac{1}{R_2} \right]$$

$$\frac{V_0}{R_2} = \left(\frac{R_1 R_2}{R_1 + R_2} \right) I_1 \left[\frac{R_2 + R_1}{R_1 R_2} \right]$$

$$\Rightarrow V_0 = I_1 R_2$$

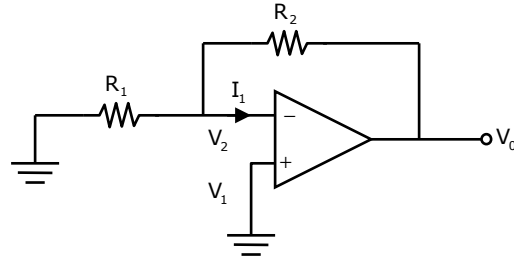

39. For the amplifier shown in the figure, the BJT parameters are $V_{BE} = 0.7V$, $\beta = 200$, and thermal voltage $V_T = 25mV$. The voltage gain (v_o / v_i) of the amplifier is _____.

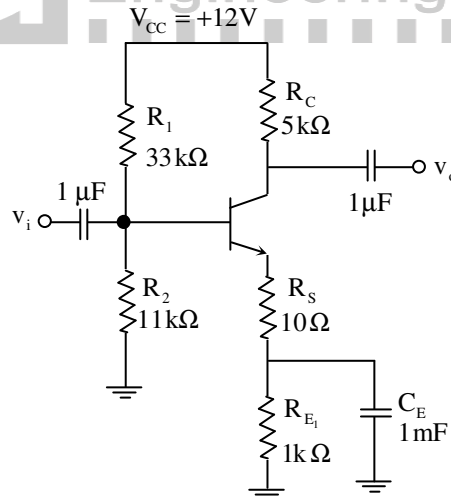

Answer: -237.76

Exp: $V_{BE} = 0.7V$, $\beta = 200$, $V_T = 25mV$

DC Analysis:

$$V_B = 12 \times \frac{11k}{11k + 33k} = 3V$$

$$V_E = 3 - 0.7 = 2.3V$$

$$I_E = \frac{2.3}{10 + 1k} = 2.277mA$$

$$I_B = 11.34 \mu A$$

$$I_C = 2.26 \text{ mA}$$

$$r_e = \frac{25 \text{ mV}}{2.277 \text{ mA}} = 10.98 \Omega$$

$$A_v = \frac{V_o}{V_i} = \frac{-\beta R_c}{\beta r_e + (1 + \beta)(R_s)} = \frac{-200 \times 5k}{200 \times 10.98 + (201)10}$$

$$A_v = -237.76$$

40. The output F in the digital logic circuit shown in the figure is

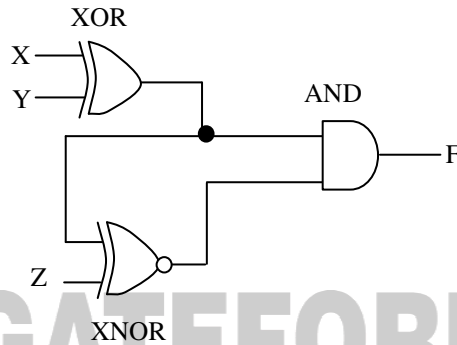

(A) $F = \bar{X}YZ + X\bar{Y}Z$

(B) $F = \bar{X}YZ + XY\bar{Z}$

(C) $F = \bar{X}\bar{Y}Z + XY\bar{Z}$

(D) $F = \bar{X}\bar{Y}\bar{Z} + XY\bar{Z}$

Answer: (A)

Exp:

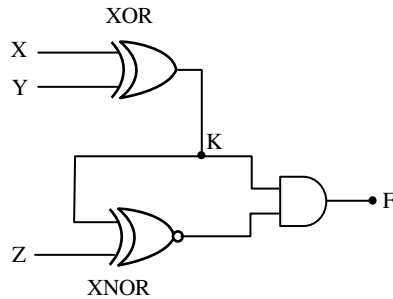

Assume dummy variable K as a output of XOR gate $K = X \oplus Y = \bar{X}Y + X\bar{Y}$

$$F = K \cdot (K \odot Z)$$

$$= (\bar{K}\bar{Z} + K.Z)$$

$$= K \cdot \bar{K}\bar{Z} + K.K.Z$$

$$= 0 + K.Z \quad (\because K \cdot \bar{K} = 0 \text{ and } K.K = K)$$

Put the value of K in above expression

$$F = (\bar{X}Y + X\bar{Y})Z$$

$$= \bar{X}YZ + X\bar{Y}Z$$

41. Consider the Boolean function, $F(w, x, y, z) = wy + xy + \overline{w}xyz + \overline{w}xy + xz + \overline{x}yz$. which one of the following is the complete set of essential prime implicants?
- (A) $w, y, xz, \overline{x}\overline{z}$ (B) w, y, xz (C) $y, \overline{x}\overline{y}\overline{z}$ (D) $y, xz, \overline{x}\overline{z}$

Answer: (D)

Exp: Given Boolean Function is

$$F(w, x, y, z) = wy + xy + \overline{w}xyz + \overline{w}xy + xz + \overline{x}yz$$

By using K-map

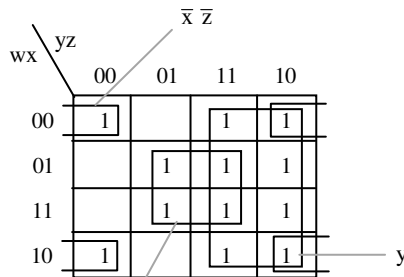

So, the essential prime implicants (EPI) are $y, xz, \overline{x}\overline{z}$

42. The digital logic shown in the figure satisfies the given state diagram when Q1 is connected to input A of the XOR gate.

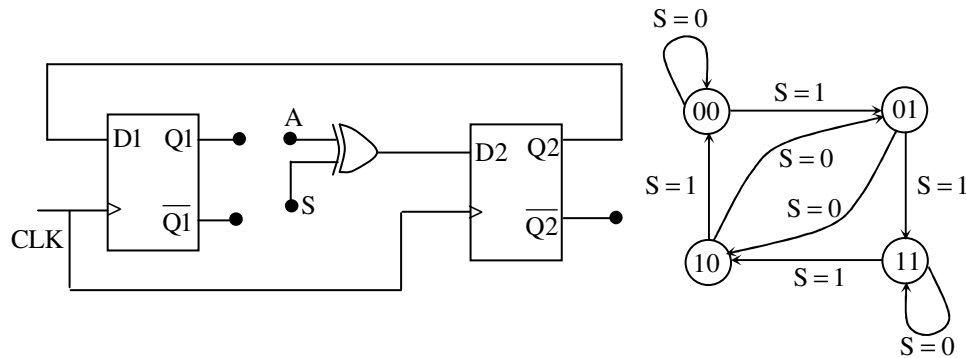

Suppose the XOR gate is replaced by an XNOR gate. Which one of the following options preserves the state diagram?

- (A) Input A is connected to $\overline{Q2}$
 (B) Input A is connected to Q2
 (C) Input A is connected to $\overline{Q1}$ and S is complemented
 (D) Input A is connected to $\overline{Q1}$

Answer: (D)

Exp: The input of D₂ flip-flop is

$$D_2 = \bar{Q}_1 S + Q_1 \bar{S} \quad (\because A=Q_1)$$

The alternate expression for EX-NOR gate is $= \overline{A \oplus B} = \bar{A} \oplus B = A \oplus \bar{B}$

So, if the Ex-OR gate is substituted by Ex-NOR gate then input A should be connected to \bar{Q}_1

$$\begin{aligned} D_2 &= \bar{Q}_1 \bar{S} + Q_1 S = \bar{\bar{Q}_1} \bar{S} + \bar{Q}_1 . S \quad (\because A = \bar{Q}_1) \\ &= Q_1 \bar{S} + \bar{Q}_1 . S \end{aligned}$$

43. Let $x[n] = \left(\frac{1}{-9}\right)^n u(n) - \left(-\frac{1}{3}\right)^n u(-n-1)$. The Region of Convergence (ROC) of the z-transform of x[n]

- (A) is $|z| > \frac{1}{9}$ (B) is $|z| < \frac{1}{3}$ (C) is $\frac{1}{3} > |z| > \frac{1}{9}$ (D) does not exist.

Answer: (C)

Exp: Given $x[n] = \left(\frac{-1}{9}\right)^n u[n] - \left(\frac{-1}{3}\right)^n u[-n-1]$

for $\left(\frac{-1}{9}\right)^n u[n]$ R_{oc} in $|z| > \frac{1}{9}$

(Right sided sequence, R_{oc} in exterior of circle of radius $\frac{1}{9}$)

Thus overall R_{oc} in $\frac{1}{9} < |z| < \frac{1}{3}$

44. Consider a discrete time periodic signal $x[n] = \sin\left(\frac{\pi n}{5}\right)$. Let a_k be the complex Fourier series coefficients of x[n]. The coefficients $\{a_k\}$ are non-zero when $k = Bm \pm 1$, where m is any integer. The value of B is_____.

Answer: 10

Exp: Given $x[n] = \sin\left(\frac{\pi n}{5}\right)$; $N = 10$

\Rightarrow Fourier series co-efficients are also periodic with period $N = 10$

$$x[n] = \frac{1}{2j} e^{j\frac{2\pi}{10}n} - \frac{1}{2j} e^{-j\frac{2\pi}{10}n}$$

$$a_1 = \frac{1}{2j}; \quad a_{-1} = \frac{-1}{2j} \Rightarrow a_{-1} = a_{-1+10} = a_9 = \frac{-1}{2j}$$

$$\left. \begin{aligned} a_1 &= a_1 + 10 \\ a_{-1} &= a_{-1} + 10 \end{aligned} \right\} \text{or } \begin{aligned} a_1 &= a_1 + 20 \\ a_{-1} &= a_{-1} + 20 \end{aligned}$$

$$\Rightarrow k = 10m + 1 \text{ or } k = 10.m - 1 \Rightarrow B = 10$$

45. A system is described by the following differential equation, where $u(t)$ is the input to the system and $y(t)$ is the output of the system.

$$\dot{y}(t) + 5y(t) = u(t)$$

When $y(0) = 1$ and $u(t)$ is a unit step function, $y(t)$ is

- (A) $0.2 + 0.8e^{-5t}$ (B) $0.2 - 0.2e^{-5t}$ (C) $0.8 + 0.2e^{-5t}$ (D) $0.8 - 0.8e^{-5t}$

Answer: (A)

Exp: Given $y(t) + 5y(t) = u(t)$ and $y(0)=1$; $u(t)$ is a unit step function.

Apply Laplace transform to the given differential equation.

$$s y(s) - y(0) + 5y(s) = \frac{1}{s}$$

$$y(s)[s+5] = \frac{1}{s} + y(0) \left[L\left[\frac{dy}{dt}\right] = s y(s) - y(0) \right] \left[L[u(t) = 1/s] \right]$$

$$y(s) = \frac{\frac{1}{s} + 1}{(s+5)}$$

$$y(s) = \frac{(s+1)}{s(s+5)} \Rightarrow \frac{A}{s} + \frac{B}{s+5}$$

$$A = \frac{1}{5}; B = \frac{4}{5}$$

$$y(s) = \frac{1}{5s} + \frac{4}{5(s+5)}$$

Apply inverse Laplace transform,

$$y(t) = \frac{1}{5} + \frac{4}{5} e^{-5t}$$

$$y(t) = 0.2 + 0.8e^{-5t}$$

46. Consider the state space model of a system, as given below

$$\begin{bmatrix} \dot{x}_1 \\ \dot{x}_2 \\ \dot{x}_3 \end{bmatrix} = \begin{bmatrix} -1 & 1 & 0 \\ 0 & -1 & 0 \\ 0 & 0 & -2 \end{bmatrix} \begin{bmatrix} x_1 \\ x_2 \\ x_3 \end{bmatrix} + \begin{bmatrix} 0 \\ 4 \\ 0 \end{bmatrix} u; y = [1 \ 1 \ 1] \begin{bmatrix} x_1 \\ x_2 \\ x_3 \end{bmatrix}$$

The system is

- (A) controllable and observable
 (B) uncontrollable and observable
 (C) uncontrollable and unobservable
 (D) controllable and unobservable

Answer: (B)

Exp: From the given state model,

$$A = \begin{bmatrix} -1 & 1 & 0 \\ 0 & -1 & 0 \\ 0 & 0 & -2 \end{bmatrix} \quad B = \begin{bmatrix} 0 \\ 4 \\ 0 \end{bmatrix} \quad c = [1 \quad 1 \quad 1]$$

$$\text{Controllable: } Q_c = c = [B \quad AB \quad A^2B]$$

if $|Q_c| \neq 0 \rightarrow$ controllable

$$Q_c = \begin{bmatrix} 0 & 4 & -8 \\ 4 & -4 & 4 \\ 0 & 0 & 0 \end{bmatrix} \Rightarrow |Q_c| = 0$$

\therefore uncontrollable

$$\text{Observable: } Q_0 = \begin{bmatrix} C \\ CA \\ CA^2 \end{bmatrix}$$

If $|Q_0| \neq 0 \rightarrow$ observable

$$Q_0 = \begin{bmatrix} 1 & 1 & 1 \\ -1 & 0 & -2 \\ 1 & -1 & 4 \end{bmatrix} \Rightarrow |Q_0| = 1$$

\therefore Observable

The system is uncontrollable and observable

47. The phase margin in degrees of $G(s) = \frac{10}{(s+0.1)(s+1)(s+10)}$ calculated using the asymptotic Bode plot is_____.

Answer: 48

$$\text{Exp: } G(s) = \frac{10}{(s+0.1)(s+1)(s+10)}$$

$$G(s) = \frac{10}{0.1 \left[1 + \frac{s}{0.1} \right] [1+s] \left[1 + \frac{s}{10} \right] \cdot 10}$$

$$G(s) = \frac{10}{[1+10s][1+s][1+0.1s]}$$

$$\text{By Approximation, } G(s) = \frac{10}{[10s+1]}$$

$$\begin{aligned} \text{Phase Margin} &= \theta = 180 + \angle GH_{\omega=\omega_{gc}} \\ &= 180 - \tan^{-1}\left(\frac{10 \times 0.99}{1}\right) \\ \text{Phase Margin} &= 95^\circ.73 \end{aligned}$$

$$\begin{aligned} \omega_{gc} = 1 &= \frac{10}{\sqrt{100\omega^2 + 1}} \\ &= 100\omega^2 = \frac{99}{1\omega} \\ &\Rightarrow \omega^2 \frac{\sqrt{99}}{1\omega} \Rightarrow \omega_{gc} = 0.9949 \text{r / sc} \end{aligned}$$

Asymptotic approximation, Phase margin = $\phi - 45^\circ \approx 48$

48. For the following feedback system $G(s) = \frac{1}{(s+1)(s+2)}$. The 2% settling time of the step response is required to be less than 2 seconds.

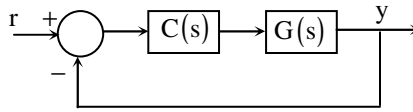

Which one of the following compensators $C(s)$ achieves this?

- (A) $3\left(\frac{1}{s+5}\right)$ (B) $5\left(\frac{0.03}{s} + 1\right)$ (C) $2(s+4)$ (D) $4\left(\frac{s+8}{s+3}\right)$

Answer: (C)

Exp: By observing the options, if we place other options, characteristic equation will have 3rd order one, where we cannot describe the settling time.

If $C(s) = 2(s+4)$ is considered

The characteristic equation, is

$$s^2 + 3s + 2 + 2s + 8 = 0$$

$$\Rightarrow s^2 + 5s + 10 = 0$$

$$\text{Standard character equation } s^2 + 2\xi\omega_n s + \omega_n^2 = 0$$

$$\omega_n^2 = \sqrt{10}; \xi\omega_n = 2.5$$

$$\text{Given, 2\% settling time, } \frac{4}{\xi\omega_n} < 2 \Rightarrow \xi\omega_n > 2$$

49. Let x be a real-valued random variable with $E[X]$ and $E[X^2]$ denoting the mean values of X and X^2 , respectively. The relation which always holds true is

(A) $(E[X])^2 > E[X^2]$ (B) $E[X^2] \geq (E[X])^2$

(C) $E[X^2] = (E[X])^2$ (D) $E[X^2] > (E[X])^2$

Answer: (B)

Exp: $V(x) = E(x^2) - \{E(x)\}^2 \geq 0$ i.e., variance cannot be negative

$$\therefore E(x^2) \geq \{E(x)\}^2$$

Function of bit energy and noise $P_{SD} \frac{N_o}{2}$

Counterllation diagram of BPSK

Channel is A_{WGN} which implies noise sample as independent

$$\text{Let } 2x + n_1 + n_2 = x^1 + n^1$$

where $x^1 = 2x$

$$n^1 = n_1 + n_2$$

$$\text{Now Bit error rate} = Q\left(\sqrt{\frac{2E^1}{N_o^1}}\right)$$

E^1 is energy in x^1

N_o^1 is PSD of h^1

$E^1 = 4E$ [as amplitudes are getting doubled]

$N_o^1 = N_o$ [independent and identical channel]

$$\Rightarrow \text{Bit error rate} = Q\left(\sqrt{\frac{4E}{N_o}}\right) = Q\left(\sqrt{2} \sqrt{\frac{2E}{N_o}}\right) \Rightarrow b = \sqrt{2} \text{ or } 1.414$$

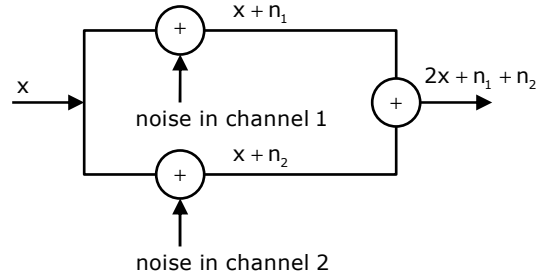
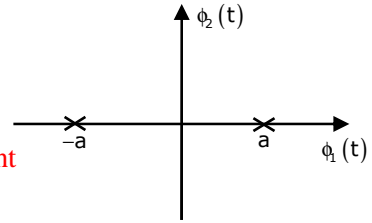

52. A fair coin is tossed repeatedly until a 'Head' appears for the first time. Let L be the number of tosses to get this first 'Head'. The entropy H(L) in bits is _____.

Answer: 2

Exp: In this problem random variable is L

L can be 1,2,.....

$$P\{L = 1\} = \frac{1}{2}$$

$$P\{L = 2\} = \frac{1}{4}$$

$$P\{L = 3\} = \frac{1}{8}$$

$$H\{L\} = \frac{1}{2} \log_2 \frac{1}{\frac{1}{2}} + \frac{1}{4} \log_2 \frac{1}{\frac{1}{4}} + \frac{1}{8} \log_2 \frac{1}{\frac{1}{8}} + \dots = 0 + 1 \cdot \frac{1}{2} + 2 \cdot \frac{1}{4} + 3 \cdot \frac{1}{8} + \dots$$

[Arithmetic gemometric series summation]

$$= \frac{2}{1 - \frac{1}{2}} + \frac{\frac{1}{2} \cdot 1}{\left(1 - \frac{1}{2}\right)^2} = 2$$

53. In spherical coordinates, let $\hat{a}_\theta, \hat{a}_\phi$ denote unit vectors along the θ, ϕ directions.

$$E = \frac{100}{r} \sin \theta \cos(\omega t - \beta r) \hat{a}_\theta \text{ V/m} \quad \text{and}$$

$$H = \frac{0.265}{r} \sin \theta \cos(\omega t - \beta r) \hat{a}_\phi \text{ A/m}$$

represent the electric and magnetic field components of the EM wave of large distances r from a dipole antenna, in free space. The average power (W) crossing the hemispherical shell located at $r = 1\text{km}, 0 \leq \theta \leq \pi/2$ is _____

Answer: 55.5

Exp: $E_\theta = \frac{100}{r} \sin \theta e^{-j\beta r}$

$$H_\phi = \frac{0.265}{r} \sin \theta e^{-j\beta r}$$

$$P_{\text{avg}} = \frac{1}{2} \int_s E_\theta H_\phi^* \cdot ds$$

$$= \frac{1}{2} \int_s \frac{100(0.265)}{r^2} \sin^2 \theta r^2 \sin \theta d\theta d\phi$$

$$P_{\text{avg}} = \frac{1}{2} \int_s (26.5) \sin^2 \theta d\theta d\phi$$

$$= 13.25 \int_{\theta=0}^{\pi/2} \sin^3 \theta d\theta \int_{\phi=0}^{2\pi} d\phi = 13.25 \cdot \left(\frac{2}{3}\right) (2\pi)$$

$$P = 55.5 \text{ w}$$

54. For a parallel plate transmission line, let v be the speed of propagation and Z be the characteristic impedance. Neglecting fringe effects, a reduction of the spacing between the plates by a factor of two results in

- (A) halving of v and no change in Z (B) no change in v and halving of Z
 (C) no change in both v and Z (D) halving of both v and Z

Answer: (B)

Exp: $Z_o = \frac{276}{\sqrt{\epsilon_r}} \log\left(\frac{d}{r}\right)$

$d \rightarrow$ distance between the two plates

so, z_o – changes, if the spacing between the plates changes.

$$V = \frac{1}{\sqrt{LC}} \rightarrow \text{independent of spacing between the plates}$$

55. The input impedance of a $\frac{\lambda}{8}$ section of a lossless transmission line of characteristic impedance 50Ω is found to be real when the other end is terminated by a load $Z_L (= R + jX)\Omega$. if X is 30Ω , the value of R (in Ω) is _____

Answer: 40

Exp:

$$\text{Given, } \ell = \frac{\lambda}{8}$$

$$Z_o = 50\Omega$$

$$Z_{in} \left(\ell = \frac{\lambda}{8} \right) = Z_o \left[\frac{Z_L + jZ_o}{Z_o + jZ_L} \right]$$

$$Z_{in} = 50 \left[\frac{Z_L + j50}{50 + jZ_L} \right] = 50 \left[\frac{Z_L + j50}{50 + jZ_L} \times \frac{50 - jZ_L}{50 - jZ_L} \right]$$

$$Z_{in} = 50 \left[\frac{50Z_L + 50Z_L + j(50^2 - Z_L^2)}{50^2 + Z_L^2} \right]$$

Given, $Z_{in} \rightarrow \text{Real}$

So, $\text{Im}(Z_{in}) = 0$

$$50^2 - Z_L^2 = 0$$

$$Z_L^2 = 50^2$$

$$R^2 + X^2 = 50^2$$

$$R^2 = 50^2 - X^2 = 50^2 - 30^2$$

$$R = 40\Omega$$

